

Deadbreak Apparatus Connectors

600 A 35 kV Class Standoff Bushings

GENERAL

The Cooper Power Systems 600 A, 35 kV Insulated Standoff Bushing meets the full requirements of **IEEE Standard 386™** — Separable Insulated Connector Systems and provides a single deadbreak interface made of high quality insulating epoxy material. It is used in pad-mounted cabinets, underground vaults, and other apparatus to isolate and sectionalize an energized cable.

Temporary or permanent parking of energized 600 A 35 kV deadbreak connectors that conform to **IEEE Standard 386™** is simplified with the use of insulated standoff bushings.

The Insulated Standoff Bushing is designed to be installed in the parking stand mounted on a transformer or other apparatus. A drain wire lug is provided on the standoff bracket for attachment of a drain wire to ensure deadfront construction. The bushing provides a fully-shielded, submersible connection for deadbreak operation.

The Cooper Power Systems 600 A, 35 kV Grounded Standoff Bushing is designed to be installed in the parking stand bracket mounted on the transformer or other apparatus.

A 2/0 AWG copper, 5-foot jacketed cable is connected to the all-aluminum bushing for attachment to system ground. The bushing provides a fully visible ground and submersible connection for temporary or permanent parking of 600 A deadbreak connectors that conform to **IEEE Standard 386™**.

All standoff bushing brackets have a stainless steel eyebolt with a brass pressure foot. The bushing body is bolted to a stainless steel base bracket using a stainless steel bolt. Special pins ensure firm location of the bushing on the bracket.

INSTALLATION

A hotstick tool is used to place the standoff bushing in the parking stand on the front plate of the apparatus. Special tools are required to thread de-energized 600 A connectors onto the standoff bushing. Refer to the appropriate connector catalog section or installation instruction for further



Figure 1. Insulated Standoff Bushing with mounting bracket, eyebolt and drain wire lug.

clarification. Refer to Installation Instruction Sheet S600-24-1 (5000050605) for complete installation details on the insulated standoff bushing. For installation of the grounded standoff bushing, refer to Installation Instruction Sheet S600-24-2 (5000050541) for details.

PRODUCTION TESTS (Insulated Standoff Bushing)

Tests conducted in accordance with **IEEE Standard 386™**:

- AC 60 Hz 1 Minute Withstand – 50 kV
- Minimum Corona Voltage Level – 26 kV

Tests conducted in accordance with Cooper Power Systems requirements:

- Physical Inspection
- Periodic Dissection
- Periodic X-ray Analysis

TABLE 1 Voltage Ratings and Characteristics — Insulated Standoff Bushing

Description	kV
Standard Voltage Class	35
Maximum Rating Phase-to-Ground	21.1
AC 60 Hz 1 Minute Withstand	50
DC 15 Minute Withstand	103
BIL and Full Wave Crest	150
Minimum Corona Voltage Level	26

Voltage ratings and characteristics are in accordance with **IEEE Standard 386™**.

TABLE 2 Current Ratings and Characteristics — Grounded Standoff Bushing

Description	Amperes
Short Time	25,000 A rms symmetrical for 0.17s

Current ratings and characteristics are in accordance with **IEEE Standard 386™**.

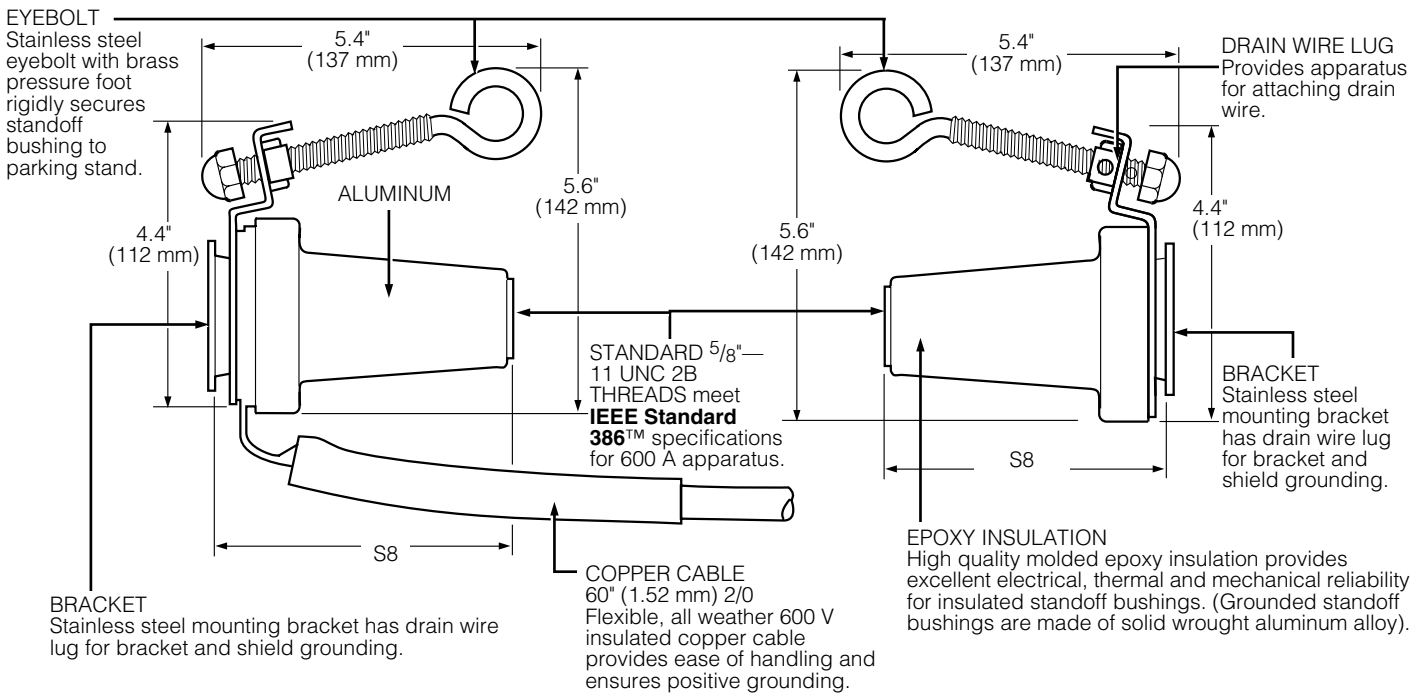

Figure 2. Grounded Standoff Bushing on left is made of aluminum alloy and has five feet of insulated cable. Insulated bushing on right is molded of epoxy insulation material.

Note: Dimensions given are for reference only.

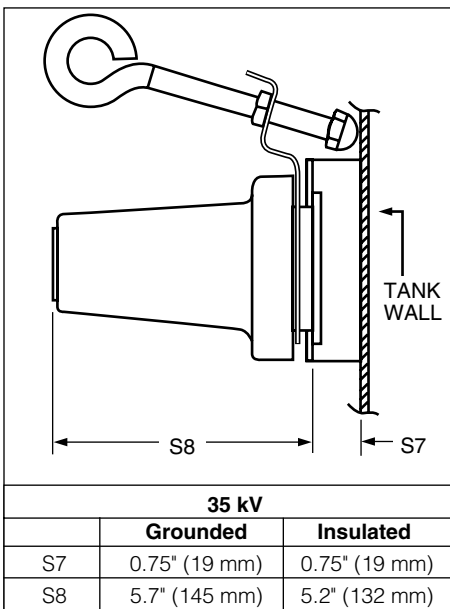

Figure 3. Standoff Bushing stacking dimensions.

ORDERING INFORMATION

To order a Cooper Power Systems 35 kV Standoff Bushing Kit, refer to Table 3.

Each kit contains:

- Standoff Bushing with Bracket
- Shipping Cap (not for energized operation)
- Silicone Lubricant
- Installation Instruction Sheet

Existing insulated or grounded bushing can be converted for use with T-OP™ II connectors by ordering and installing the copper alloy T-OP II** stud.

****If a T-OP II STUD (STUD-T) is installed in an existing insulated or grounded bushing the short end of the stud must be threaded into the bushing.**

****The T-OP II STUD (STUD-T) should only be used when grounding or achieving a visible break of a Cooper T-OP II termination.**

**TABLE 3
Ordering Selection Guide**

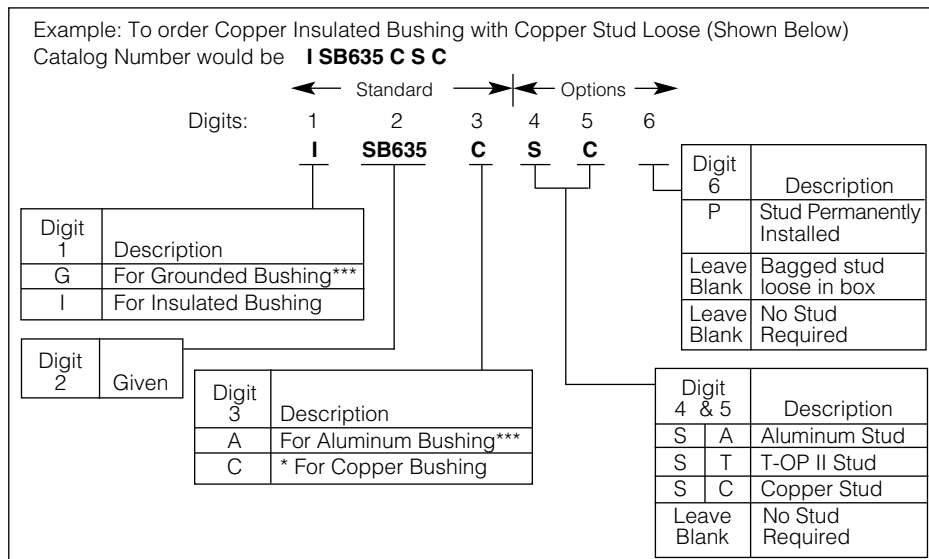

* Cooper Power Systems recommends when a copper Standoff is designated – use only copper stud or T-OP II stud.

*** Grounded bushing available in solid wrought aluminum alloy only. Digit 3 will be "A".

ISO 9001:2000-Certified Quality Management System



© 2003 Cooper Industries, Inc.
T-OP™ II is a trademark of Cooper Industries, Inc.
IEEE Standard 386™ is a trademark of Institute of Electrical and
Electronics Engineers, Inc.

1045 Hickory Street
Pewaukee, WI 53072 USA
www.cooperpower.com